

THIS DRAWING IS UNPUBLISHED. RELEASED FOR PUBLICATION  
 © COPYRIGHT BY TYCO ELECTRONICS CORPORATION. ALL RIGHTS RESERVED.

LOC	DIST	REVISIONS					
AJ	16	P	LTR	DESCRIPTION	DATE	DWN	APVD
		C2		REVISED PER ECO-08-000700	2/5/2008	DW	BW

- 1. CRIMP FERRULE USING CRIMP DIE HEX SIZE SPECIFIED IN TABLE.
- 2. SINGLE PACKED
- 3. BULK PACKED IN QUANTITIES OF 100
- 4. ASSEMBLE USING INSTRUCTION SHEET IS 408-8817

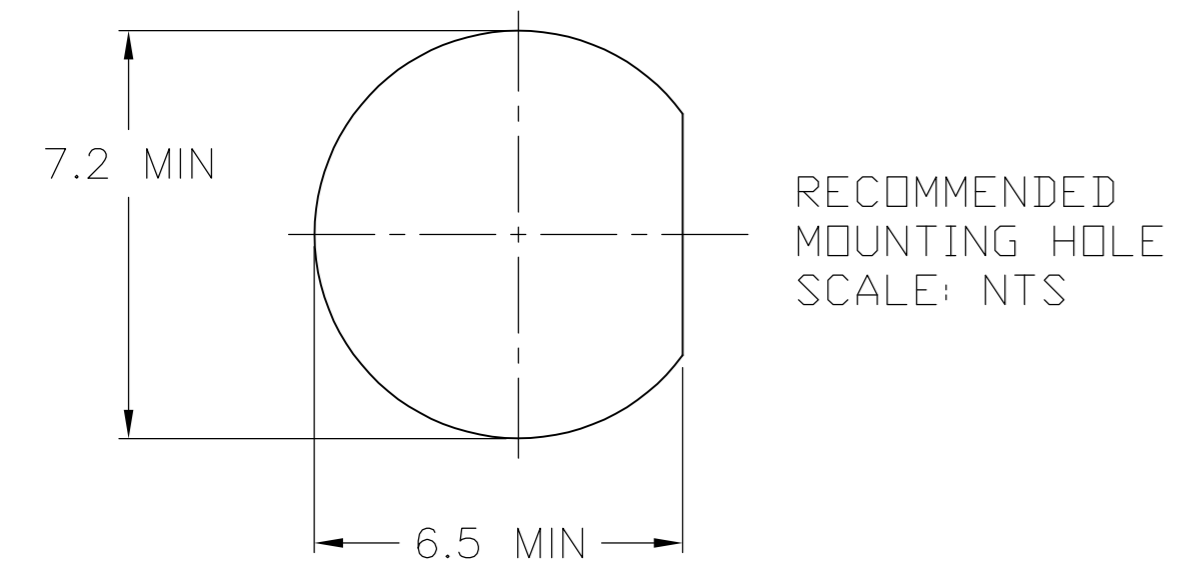
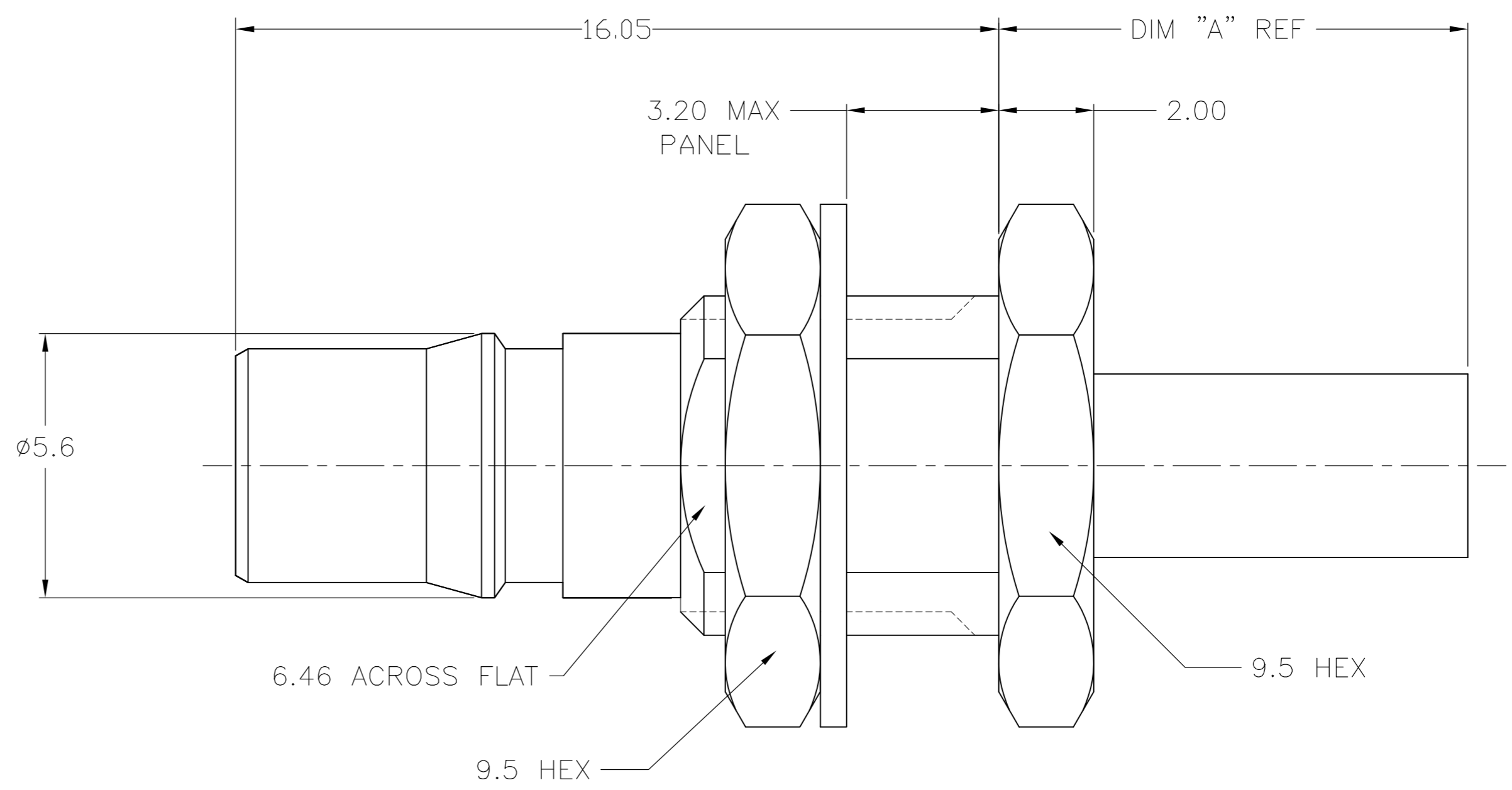
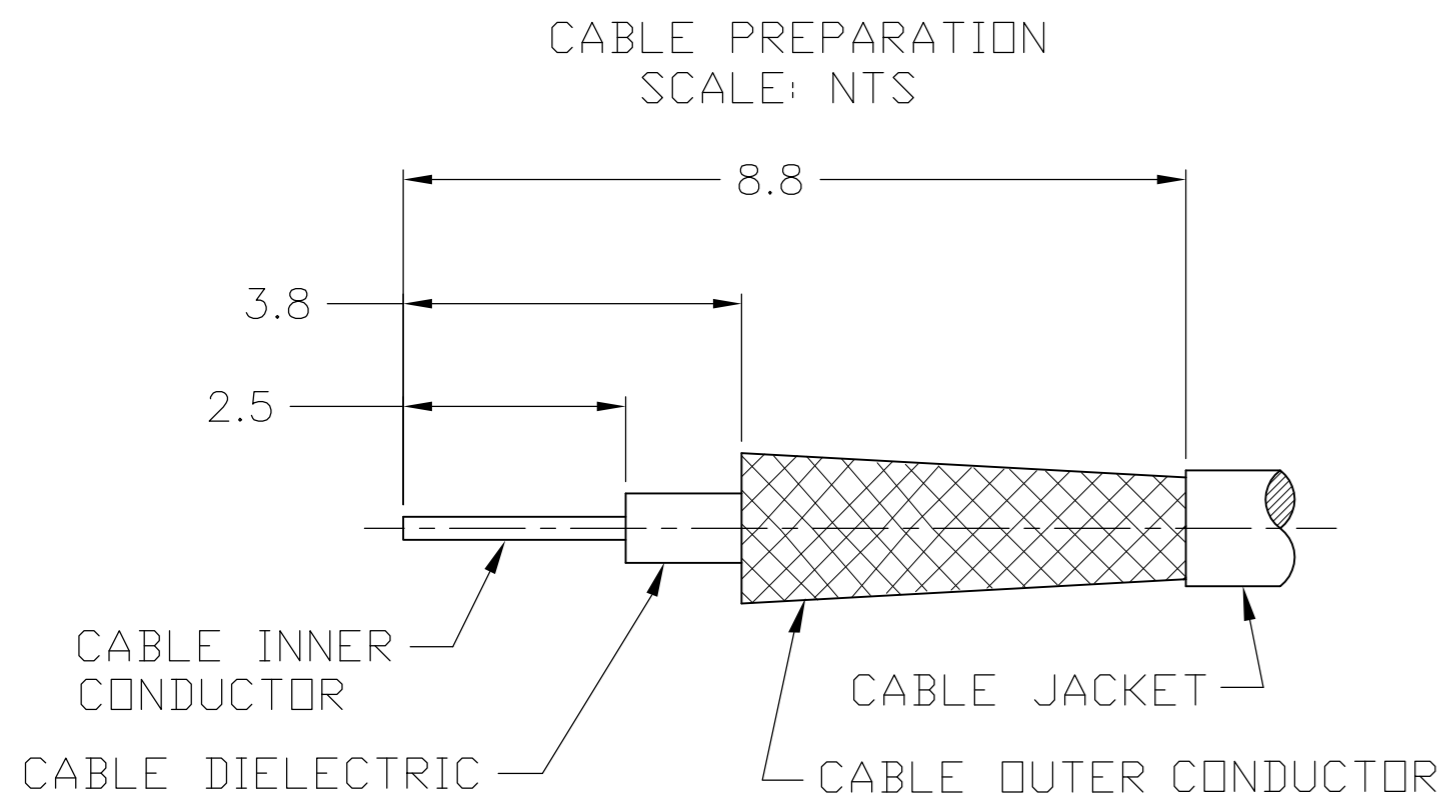

3	12.2	5.41	RG58/U, 141, 303 & SF142	8-1403077-0	5-1403080-8	1408411-8	9-446556-2	1408408-2	1408339-8
2	12.2	5.41	RG58/U, 141, 303 & SF142	8-1403077-0	5-1403080-8	1408411-8	9-446556-2	1408408-2	1408339-7
3	12.2	5.41	RG55/U, 142, 223 & 400	8-1403077-0	5-1403080-8	1408411-8	2-1403102-5	1408408-2	1408339-6
2	12.2	5.41	RG55/U, 142, 223 & 400	8-1403077-0	5-1403080-8	1408411-8	2-1403102-5	1408408-2	1408339-5
3	9.9	3.83	RD316/U	8-1403077-0	5-1403080-8	1408411-4	2-413889-7	1408408-1	1408339-4
2	9.9	3.83	RD316/U	8-1403077-0	5-1403080-8	1408411-4	2-413889-7	1408408-1	1408339-3
3	9.9	3.25	RG316/U, 174 & 188	8-1403077-0	5-1403080-8	1408411-4	2-413889-4	1408408-1	1408339-2
2	9.9	3.25	RG316/U, 174 & 188	8-1403077-0	5-1403080-8	1408411-4	2-413889-4	1408408-1	1408339-1
PACK	DIM A	HEX	CABLE	MTG NUT	WASHER	CONTACT	FERRULE	HSG ASSY	PART NO.

CENTER CONTACT	BERYLLIUM COPPER	GOLD
HOUSING NUT	BRASS	NICKEL
FERRULE	COPPER OR BRASS	NICKEL
WASHER	BRONZE	NICKEL
DIELECTRIC	PTFE	N/A
COMPONENT	MATERIAL	FINISH

THIS DRAWING IS A CONTROLLED DOCUMENT.

DWN	DCam	25SEP2002
CHK	DG	4/15/03
APVD	DCam	4/15/03
PRODUCT SPEC	108-2087	
APPLICATION SPEC	-	
WEIGHT	-	
CUSTOMER DRAWING	-	

Tyco Electronics Corporation  
Harrisburg, PA 17105-3608

QMA STRAIGHT CABLE JACK CRIMP ATTACHMENT

SIZE	CAGE CODE	DRAWING NO	RESTRICTED TO
A2	00779	C=1408339	-
SCALE	SHEET	REV	
10:1	1 of 1	C2	